

The Cross Pitot Primary (AF-XPP) represents a significant advance in air flow measurement. It uses four proven techniques to maximize reliability and accuracy:

1. The pitot is internally manifolded into a measurement system that averages all four flow quadrants. A sensor measuring in all four quadrants is more likely to measure correctly in a duct which has a poor profile than one that only measures the flow in one plane.
2. By using the Parallel Plate Pitot (AF-PPP) as the sensing element, the pitot's maximum velocity range and accuracy are enhanced, particularly in the low range. The AF-PPP will operate in a poor profile air stream similar to a pitot with "honeycomb" or straightening vanes, but without the plugging problems usually associated with them.
3. By installing the pitot in a thick-walled duct section, a beta ratio (the ratio of the measurement section to the entrance section) of less than one can be obtained. This technique makes the measurement section less sensitive to upstream conditions and, due to its structural stiffness, the internal area less likely to be affected by installation.
4. The pitot's uniquely ported total-pressure sensing holes allow the pitot to perform a velocity vs. typical pressure average. This results in a pitot that is more accurate under poor duct profile conditions and reduces the requirements for a straight duct run.

APPLICATIONS

- ▼ Continuous air flow control
- ▼ Continuous air or compatible gas measurement
- ▼ Mass flow measurement (with temperature correction)
- ▼ Laboratory exhaust flow
- ▼ Room supply flow control
- ▼ Room exhaust flow control
- ▼ Room or building air volume measurement
- ▼ Volumetric synchronization of laboratories and buildings
- ▼ Monitoring test facilities
- ▼ Measuring for regulatory compliance

ADVANTAGES

- ▼ Accuracy
- ▼ Low unrecovered pressure loss
- ▼ Resists plugging
- ▼ Low "noise" operation
- ▼ All materials in contact with the flowing stream made of chemically inert PVC or passivated aluminum
- ▼ In-place calibration not normally required

OPERATION

Due to the velocity averaging aspect of the specially ported total-pressure sensing holes, the AF-XPP only requires a straight duct run equal to 2 diameters upstream and equal to 1 diameter downstream. (Operation with other than standard conditions will require in-place calibration for maximum accuracy.) The flow control system can easily accommodate temperature input for mass flow calculations. Temperature affects the pitot's mass flow measurement by about 1%/10°F.

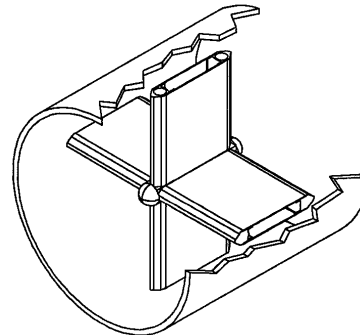

View of Cross Pitot (AF-XPP) Inside Duct Section

NOTE: AF-XPP does not include duct section

(1%/5.6°C)

Under extremely turbulent conditions, the output of the pitot must be linearized prior to time averaging. When used with low volume transmitters a special "pneumatic capacitor" may be required to decouple the acoustical noise and force equal response rate characteristics.

SPECIFICATIONS

- ▼ **Maximum Static Pressure:** 15 psig (103 kPa)
- ▼ **Maximum Operating Temperature:** 160°F (71°C)
- ▼ **Wetted Materials:** schedule 40 PVC casing and PVC pitot (stainless steel or aluminum optional)
- ▼ **Output Connections:** 1/8 in. FNPT
- ▼ **Velocity Range:** 50 to 6000 fpm (0.254 to 30.5 m/s)
- ▼ **Unrecovered Pressure Loss:** 0.1 x velocity pressure
- ▼ **Accuracy (Over any 5:1 flow range):** 1% (includes linearity and hysteresis)
- ▼ **Relative Accuracy (5:1 flow range):** accuracy as compared to the customer stated reference $\pm 1\%$ with standard upstream conditions (testing may be required)
- ▼ **AE (Effective Area):** stamped on the meter label (size and test method dependent)

AF-XPP

CALCULATIONS

General relationship: $Q = V \times A_E$, where Q is volume flow, V is velocity, and A_E is effective area of the MPP.

Example: Air at standard conditions inside an AF-XPP-10 with $A_E = 0.429 \text{ ft}^2$, and 800 cfm:

$$V = 4005 \times \sqrt{\Delta h}$$

$$Q = A_E \times 4005 \times \sqrt{\Delta h}$$

$$\Delta h = \left(\frac{Q}{A_E \times 4005} \right)^2 = \left(\frac{800}{0.429 \times 4005} \right)^2 = 0.212 \text{ in wc}$$

Conversely, if a 0.25 in. wc transmitter were on this pitot, full scale flow at standard conditions would be:

$$Q = A_E \times 4005 \times \sqrt{\Delta h} = 0.429 \times 4005 \times \sqrt{0.25} = 859 \text{ cfm}$$

A more general relationship for V for any fluid is:

$$V = 1097 \times \sqrt{\frac{\Delta h}{\rho}}$$

where ρ is density (lb/ft³) and Δh is differential pressure (in. wc)

Also, for dry air:

$$\rho = \frac{1.325 \times P_B}{T}$$

where P_B is barometric pressure in inches of mercury, and T is absolute temperature in °R (460 + °F)

PHYSICAL DIMENSIONS

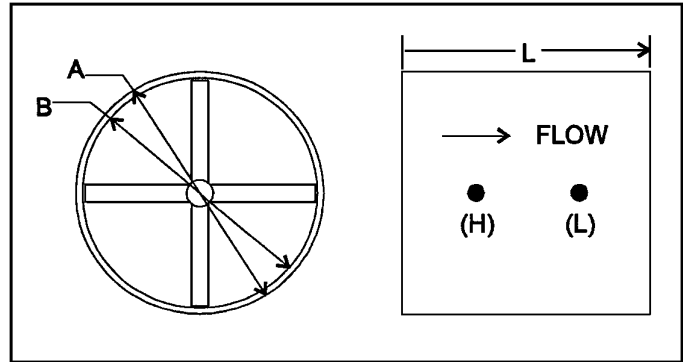

NOM	A	B	L	A_E
6.0 (15.24)	6.63 (16.84)	6.03 (15.32)	6.0 (15.24)	0.147 (136.58)
8.0 (20.32)	8.63 (21.92)	7.94 (20.17)	8.0 (20.32)	0.258 (239.71)
10.0 (25.40)	10.75 (27.31)	9.98 (25.35)	10.0 (25.40)	0.429 (398.57)
12.0 (30.48)	12.75 (32.39)	11.89 (30.20)	12.0 (30.48)	0.638 (592.76)
14.0 (35.56)	14.0 (35.56)	13.07 (33.20)	13.0 (33.56)	0.770 (715.40)
16.0 (40.64)	16.0 (40.64)	14.94 (37.94)	15.0 (38.10)	1.03 (956.96)

Dimensions in inches (cm); A_E in ft.² (cm²). Use A_E for estimating purposes only. Actual value stamped on device.

ORDERING INFORMATION

AF-XPP-16	16 in. (40.6 cm) nominal, with schedule PVC casing and pitot
-----------	--

Aluminum and stainless steel pitots are available as special order items.

WORLD HEADQUARTERS

American Auto-Matrix
 One Technology Lane
 Export, Pennsylvania 15632-8903 USA
 Tel (1) 724-733-2000
 Fax (1) 724-327-6124
 Email aam@aamatrix.com
 www.aamatrix.com



AMERICAN AUTO-MATRIX®

part no. 1E-05-00-0109