

AF-DPR-A™ Precision Damper Assembly

DESCRIPTION

In Critical Environments, it is common for installations to use generic air control butterfly damper assemblies commonly made of thin gauge sheet metal with pressed bearings. In many observed situations, these generic solutions have proven to be unreliable in continuous usage control strategies, leading to increased cost in energy management, on-going service, and overall ownership in a Critical Environment investment.

Through our years of expertise in Critical Environments, American Auto-Matrix® has developed a robust Precision Damper Assembly (AF-DPR-A) to provide a superior solution for installations. Unlike generic assemblies made from thin sheet metal, the Auto-Flow assembly is made of extruded, thick-walled Schedule 40 Type 1 polyvinyl chloride. This design provides excellent structural stiffness and accurate bore, as well as general resistance to most acids, bases, and other chemical solutions commonly found in laboratory environments. Contained within the assembly is a damper blade manufactured of Grade 304 stainless-steel. The use of stainless steel on the damper blade provides excellent corrosion resistance in a wide range of atmospheric environments and corrosive medias, as well as good heat and oxidation resistance. Bearings are made of PEEK for low friction and high corrosion resistance.

Combined with the structural design of the product, Auto-Flow Precision Damper Assembly not only reduces cost for installation and ownership, but provides a durable and robust solution capable of performing reliably when needed the most.

Supplied with high-speed feedback actuator capable of 90° rotation in 1-5 seconds (AF-ACT1)

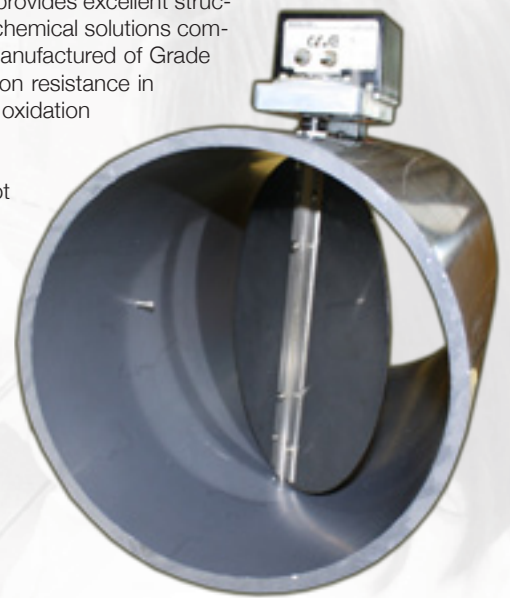

APPLICATIONS

- ▼ Continuous flow control of airflow
- ▼ Fume hood flow control
- ▼ Laboratory exhaust flow
- ▼ Room supply flow control
- ▼ Room exhaust flow control
- ▼ Room pressurization

ADVANTAGES

- ▼ High turn-down without rubber seals
- ▼ Damper body will not warp during installation
- ▼ All materials in contact with the flowing stream made of chemically inert PVC or stainless steel
- ▼ Damper blade made of 304 stainless steel
- ▼ Superior low dead band characteristics - no loss of motion in linkages
- ▼ Smooth movement from the low-friction damper
- ▼ When used with an AF-ACT-1 actuator, the AF-DPR-A reaches 70% (or greater) open position on loss of power
- ▼ Long life even at high speed operation
- ▼ Low pressure drop in fully open position

AF-DPR-A SPECIFICATIONS	
Maximum Static Pressure	4 in. wc (996 Pa)
Maximum Operating Temp	125° F (51.7° C)
Maximum Torque (any position, no flow)	0.075 in. lbf (0.0085 N-m)
Damper Body	schedule 40 Type 1 PVC
Damper Blade Material	stainless steel
Maximum Combined Unrecovered Pressure Loss (damper > 90% open)	0.15 x velocity pressure
Internal Hardware	stainless steel
Bearings	polyethyl ether ketone (PEEK)

OPERATIONAL NOTES

1. Unless otherwise stated, the damper will be configured in the normally open mode (damper is in the fully open position on loss of power).
2. In-line actuator mounting is the most common configuration.
3. The damper default position is normally open. It may be field changed to normally closed.
4. Product may be ordered with cross-flow Pitot Tube installed (specify -AP)

PHYSICAL DIMENSIONS

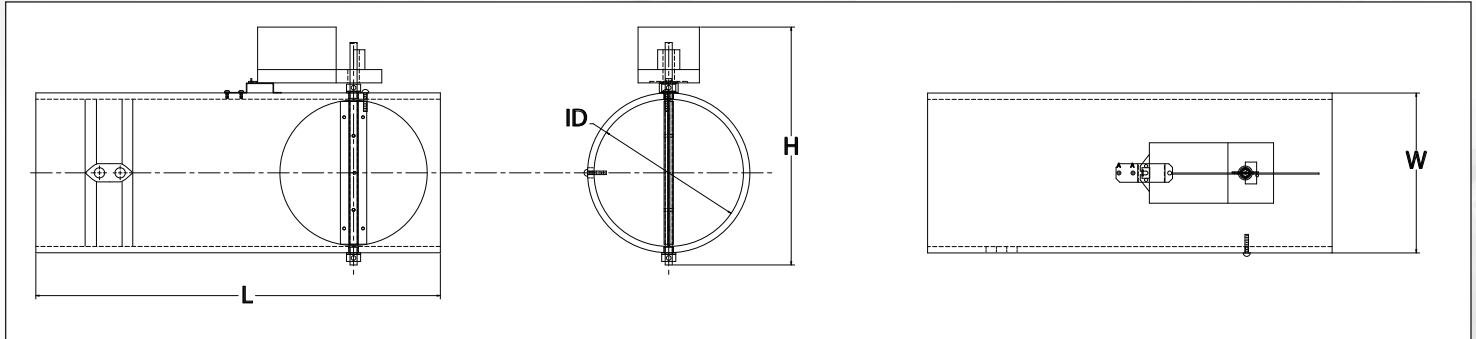

MODEL	L	W	H	ID
AF-DPR-08-A	21.5 (54.61)	8.63 (21.92)	12.83 (32.59)	7.94 (20.16)
AF-DPR-10-A	29.0 (73.66)	10.75 (27.31)	14.95 (37.97)	9.98 (25.27)
AF-DPR-12-A	29.0 (73.66)	12.75 (32.39)	16.95 (43.05)	11.89 (30.20)

inches (cm)

MODEL	AF-DPR-08-A	AF-DPR-10-A	AF-DPR-12-A
minimum cfm* damper closed 1 in. wc static** (minimum m ³ /m ³ * @249 Pa static**)	35 (0.991)	44 (1.246)	65 (1.841)
cfm* flow @ 2000 fpm duct velocity (m ³ /m ³ * @ 10.15 m/s)	689 (19.51)	1088 (30.81)	1544 (43.72)
unrecovered pressure loss in. wc (Pa) > 90% open (.15 x velocity pressure)	0.039 (9.711)	0.039 (9.711)	0.039 (9.711)

*at standard conditions

** to find new minimum cfm (m³/m) for different static pressures, multiply minimum cfm (m³/m) by square root of static pressure in. wc (Pa)

ORDERING INFORMATION

AF-DPR-08-A	8 in. (20.20 cm) nominal, PVC casing
AF-DPR-10-A	10 in. (20.20 cm) nominal, PVC casing
AF-DPR-12-A	12 in. (20.20 cm) nominal, PVC casing



American Auto-Matrix products and systems are manufactured and installed under one or more of the following US patents and/or others that may apply.
5,764,579; 6,272,399; 5,920,488; 5,946,221; 5,481,919; 5,402,687; 5,415,583

American Auto-Matrix
One Technology Lane
Export, PA 15632

TEL (1) 877-AAM-HVAC
FAX (1) 724-327-6124

AAM@AAMATRIX.COM

WWW.AAMATRIX.COM

Appropriate safety precautions must always be taken when operating or maintaining equipment connected to any American Auto-Matrix product or other Licensed Materials or Hardware. AAM assumes no responsibility or liability for any injuries or damage to any persons or property resulting from the use of these products. As always, these products should be used in the manner they are intended.

Auto-Flow, American Auto-Matrix, the American Auto-Matrix logo, the Rocket-A and Smart Building Solutions are registered trademarks of American Auto-Matrix. USGBC and related logo is a registered trademark of U.S. Green Building Council and is used with permission.

© 2011 AMERICAN AUTO-MATRIX



American Made
American Owned

Part No : 1E-05-00-0062